



INSTRUCTION MANUAL FOR
MC PNEUMATIC QUICK VISE
Model PQV- 100, 130, 160, 200,



SAFEWAY MACHINERY INDUSTRY CORPORATION

FEATURES:

1. Robust construction of one piece casting consisting of fixed jaw and vise bed.
2. Rigid casting of high tensile ductile iron FCD60JIS (Equal to GGG60) with 60 kgs/mm² or 80,000 psi tensile strength.
3. Suitable for mass production runs on machine centers, milling machines, drilling machines or special purpose machines.
4. Compact pneumatic mechanism design. No oil is required only a air supply.
5. Compact total length of vise with Max. clamping capacity
6. Safety locking mechanism for unexpected termination of air supply. After pneumatic clamping, the work piece will be remain clamped firmly even without the air supply.
7. Easy and simple ON-OFF switch control for pneumatic operation. Optional electric control can be supplied for automatic operation or as a FMS system.
8. Safety protection with Max. pneumatic clamping stroke is 4 mm to prevent inserting operator's finger during clamping operation. (Stroke is 2mm best power capacity)
9. Rapid ON-OFF only 1.5sec.
10. Multiply vises can be set up and controlled with only one source of air supply. (Optional)
11. Free adjusting of Max. pneumatic clamping pressure from 0-1,000 kgf (4000) by air regulator, jaw opening 2 mm is best clamping power capacity of workpiece.
12. Vise bed flame hardened to HRC45° to reduce wear and maintain accuracy.
13. Down trust "semi-spherical segment" mechanism eliminates the jaw and work-piece lifting

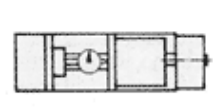
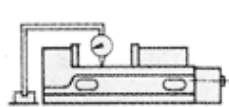
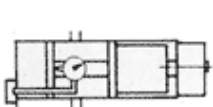
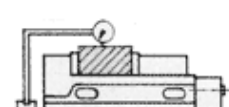
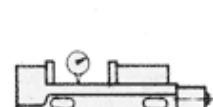
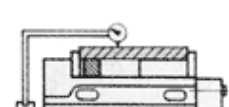
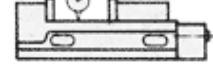
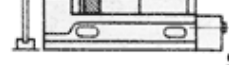
NO	TEST REPORT	JIS grade 1.	GUARANTEED		
1	Both jaw plate parallel	0.020 100mm	0.020 100mm		
2	Keyways on bottom of vise bed square to clamping surface of jaw plate.	0.020 100mm	0.015 100mm		
3	Vise side-lock on bottom to slide way square.	0.020 100mm	0.010 100mm		
4	Surface of vise bed parallel to bottom of vise body.	0.020 100mm	0.010 100mm		
5	Top of rectangular test block clamped tightly by jaw parallel to bottom of vise body	0.030 100mm	0.020 100mm		
6	Max. opening test block parallel to bottom of vise body.	0.050 100mm	0.030 100mm		

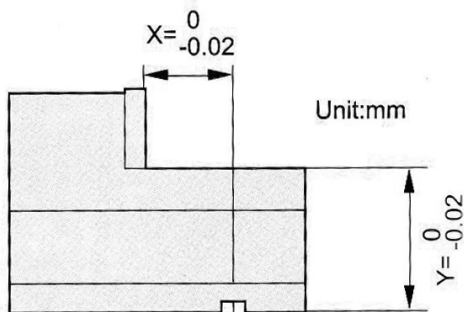

V=YES

S=NO

PQV-100V, 130V, 160V, 200V

 $X = \begin{matrix} 0 \\ -0.02 \end{matrix}$ $Y = \begin{matrix} 0 \\ -0.02 \end{matrix}$

Vise side-lock square within 0.010mm

PQV-100S, 130S, 160S, 200S

Vise side-lock square without control

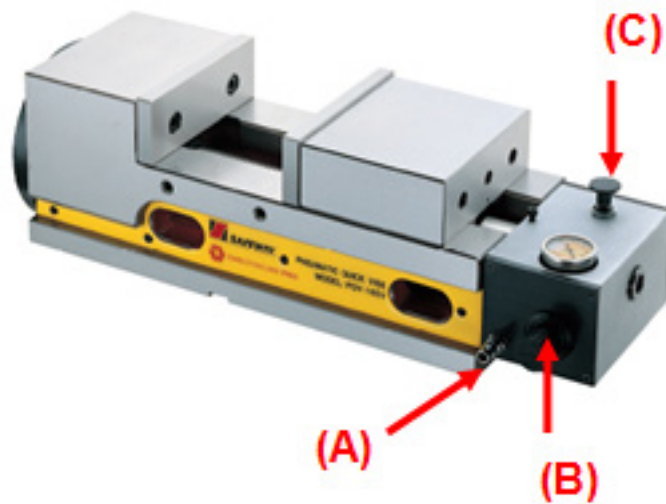

1.1 Air Supply To Vice

(1) Connecting the vice to the air compressor from the air hose nipple (called part no. A). For the best result use a hose with 12mm inside diameter. A hose with 10mm inside diameter can be used but the pressure may be reduced.

(2) Depending on the requirements the pressure regulator (called part no. B) may be adjusted. To adjust the regulator press down on the knob of the pressure regulator then rotate clockwise. The pressure gauge will display how much pressure you have selected.

*The original value of Pressure regulator is 6kg/cm²

1.2 How to clamp the workpiece

1) To prepare the vice for clamping, firstly make sure that the button (C) is in the upward position. Turn the handle anticlockwise and the jaw will be opened accordingly. Place the workpieces in the vice and close the vice by turning the handle clockwise until the jaw opening is within 2 mm of the clamped position. This will give the best clamping power capacity on the workpieces.

2) To close the vice press the button (C) to the downward position and the jaw will close.

1.3 How to un-clamp the workpieces :

1) The work piece is released by pulling up the button of the operating valve (C)
The jaw will open automatically and the work piece can be removed.

Note: When setting up the vice please consider the correct jaws for the application. For cast products with rough surfaces will require serrated jaws such as the “RJ” series. Standard jaws will, due to the rough surface, be not as effective in clamping the work piece.

(See jaw selection on the next pages.)



SAFEWAY

ISO-9001:2000



SPECIAL APPLICATION JAW PLATES

Unit:mm

(HARDENED HRC55°~58°)
PJ-100S, 130S, 160S, 200S, 250S
PJ-100V, 130V, 160V, 200V, 250V (E=0.02)

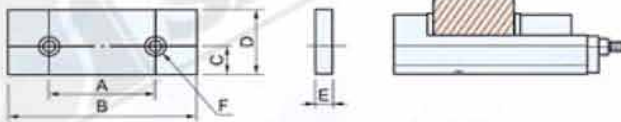

	07888002	07888006	07888010	07888014	07888018
PJ	100	130	160	200	250
A	60	90	90	120	160
B	100	130	160	200	250
C	22	25	25	28	35
D	48	55	58	63	80
E	15	15	15	18	21
F	M10x20L	M10x20L	M10x20L	M12x25L	M12x25L

(HARDENED HRC55°~58°)
RJ-100S, 130S, 160S, 200S, 250S
RJ-100V, 130V, 160V, 200V, 250V (E=0.02)

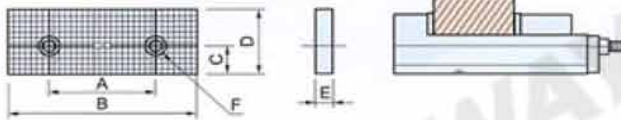

	07888022	07888026	07888030	07888034	07888038
RJ	100	130	160	200	250
A	60	90	90	120	160
B	100	130	160	200	250
C	22	25	25	28	35
D	48	55	58	63	80
E	15	15	15	18	21
F	M10x20L	M10x20L	M10x20L	M12x25L	M12x25L

(HARDENED HRC55°~58°)(FOR DAV)
PJ-1001, 1301, 1601, 2001
PJ-1002, 1302, 1602, 2002

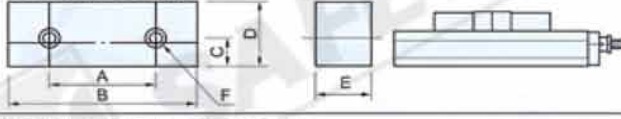

	07888132	07888136	07888140	07888144	07888148	07888152	07888156	07888160
PJ	1001	1301	1601	2001	1002	1302	1602	2002
A	60	90	90	120	60	90	90	120
B	100	130	160	200	100	130	160	200
C	22	25	25	28	22	25	25	28
D	48	55	58	63	63	73	73	102
E	48	48	48	63	48	48	48	63
F	M10x50L	M10x50L	M10x50L	M12x65L	M10x50L	M10x50L	M10x50L	M12x65L

(HARDENED HRC55°~58°)(FOR DAV)
RJ-1003, 1303, 1603, 2003
RJ-1004, 1304, 1604, 2004

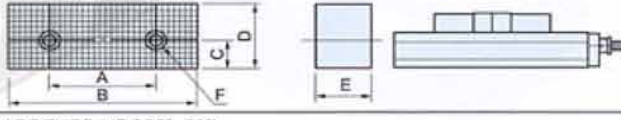

	07888164	07888168	07888172	07888176	07888180	07888184	07888188	07888192
RJ	1003	1303	1603	2003	1004	1304	1604	2004
A	60	90	90	120	60	90	90	120
B	100	130	160	200	100	130	160	200
C	22	25	25	28	22	25	25	28
D	48	55	58	63	63	73	73	102
E	48	48	48	63	48	48	48	63
F	M10x50L	M10x50L	M10x50L	M12x65L	M10x50L	M10x50L	M10x50L	M12x65L

(HARDENED HRC55°~58°)
DJ-100, 130, 160, 200

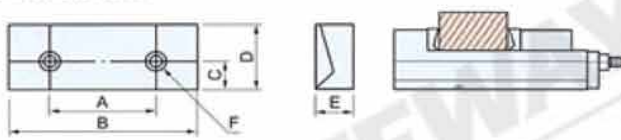

	07888042	07888044	07888046	07888048
DJ	100	130	160	200
A	60	90	90	120
B	100	130	160	200
C	22	25	25	28
D	48	55	58	65
E	32	32	32	32
F	M10x20L	M10x20L	M12x20L	M12x25L

(HARDENED HRC55°~58°)
CJ-100, 130, 160, 200, 250

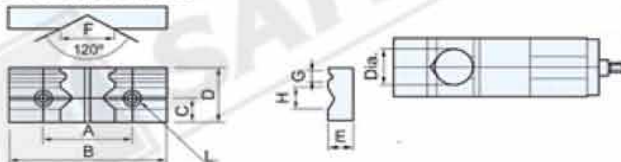

	07888050	07888052	07888054	07888056	07888058
CJ	100	130	160	200	250
A	60	90	90	120	160
B	100	130	160	200	250
C	22	25	25	28	35
D	48	55	58	63	80
E	24	24	30	36	36
F	55	55	55	70	70
G		12	12	12	12
H	25	25	25	30	30
L	M10x16L	M10x16L	M10x16L	M12x16L	M12x16L
Dia	40-100	40-100	40-100	50-140	50-140

(HARDENED HRC55°~58°)
CJ-1005, 1305, 1605, 2005, 2006

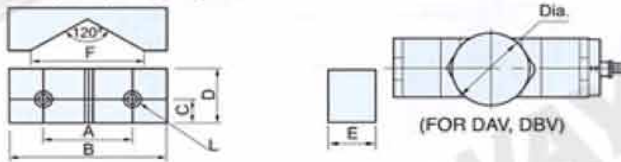

	07888240	07888242	07888244	07888246	07888248
CJ	1005	1305	1605	2005	2006
A	60	90	90	120	120
B	100	130	160	200	200
C	22	25	25	28	28
D	48	55	58	63	63
E	42	48	48	48	63
F	94	120	120	120	184
G					
H					
L	M10x16L	M10x16L	M10x16L	M12x16L	M12x16L
Dia	100-180	100-230	100-230	110-220	220-340

(HARDENED HRC55°~58°)
LJ-100S, 130S, 160S, 200S
LJ-100V, 130V, 160V, 200V (E=0.02)

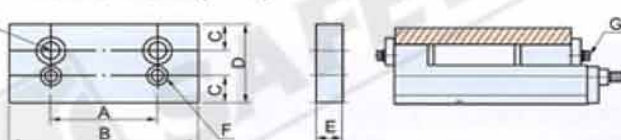

	07888060	07888064	07888068	07888072
LJ	100	130	160	200
A	60	90	90	120
B	100	130	160	200
C	22	25	25	28
D	63	69	73	88
E	21	23	23	30
F	M10x25L	M10x30L	M10x30L	M12x35L
G	M12x45L	M12x45L	M14x55L	M16x65L



SPECIAL APPLICATION JAW PLATES 特殊虎口

Unit:mm

階梯虎口 (Hardened / 熱處理 HRC55°~58°) SJ-100S,130S,160S,200S,250S (不定規格) SJ-100V,130V,160V,200V,250V (定寸規格) (E,L,G=0 -0.02)

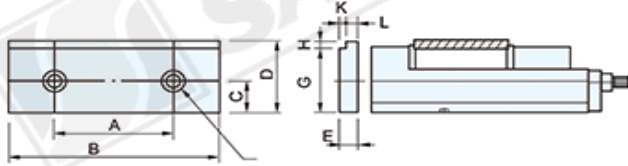

Table with 5 columns (SJ, 07888076, 07888080, 07888084, 07888088, 07888090) and 12 rows (SJ, A, B, C, D, E, F, G, H, K, L) listing dimensions for various jaw plate models.

SOFT JAW / 軟質虎口 (Without Hardened & Ground / 無熱處理, 無研磨) FJ-1001,1002,1003 FJ-1301,1302,1303 FJ-1601,1602,1603 FJ-2001,2002,2003

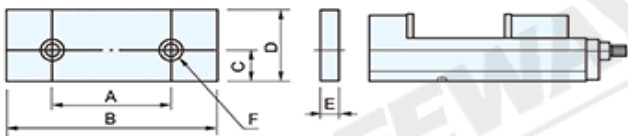

Table with 2 columns of dimensions (FJ, A, B, C, D, E, F) and 12 rows listing dimensions for soft jaw plate models.

SOFT JAW / 加厚軟質虎口 (Without Hardened & Ground / 無熱處理, 無研磨) FJ-1004,1005 FJ-1304,1305 FJ-1604,1605 FJ-2004,2005

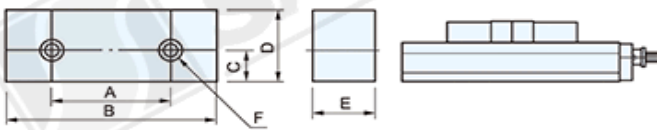
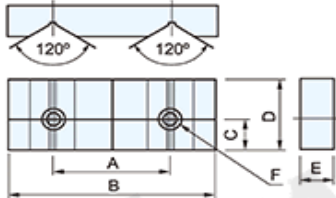

Table with 2 columns of dimensions (FJ, A, B, C, D, E, F) and 12 rows listing dimensions for thick soft jaw plate models.

DOUBLE V JAW / 雙V虎口 (Hardened / HRC55°~58°) VJ-100,130,160,200



PATENTED / 專利在案

1 pc double v jaw+1 set balance jaw plates, it can be do 2 different size parts 一雙V虎口加一組離離板虎口, 可做兩只大小不一異形工件

1 pc flat jaw plate+1set balance jaw plates, it can be do 2 different clearance parts 一平蓋虎口加一組離離板虎口, 可做兩只大小不一工件

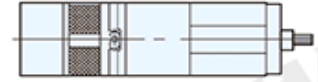
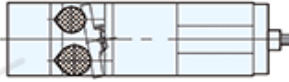

2 Sets balance jaw plates (hardened) it can be do angle part 兩組離離板虎口(硬質虎口), 可做一只單斜度或雙斜度工件

2 Set balance jaw plates (soft) it can be do 2 irregular parts 兩組離離板虎口(軟質虎口), 可做兩只不規則形狀工件(不規則形狀自行磨削成形)

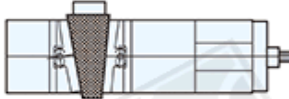

BALANCE JAW / 翹翹板虎口 (Hardened / 熱處理 HRC55°~58°) TJ-100,130,160,200

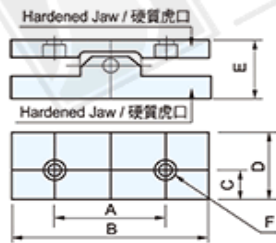

BALANCE JAW / 翹翹板虎口 (Soft Jaw Plate / 軟質虎口) TJ-100F,130F,160F,200F

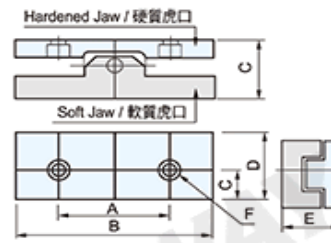

Table with 8 columns (A, B, C, D, E, F, REMARK) and 12 rows listing dimensions and remarks for balance jaw plate models.

STEP GUIDE KEY / 階梯鍵 (Hardened / 熱處理 HRC55°~58°) 全部精密研磨

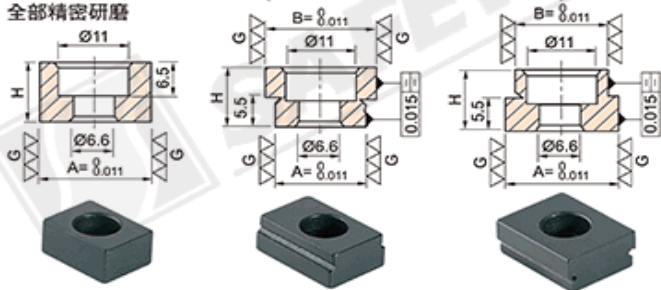
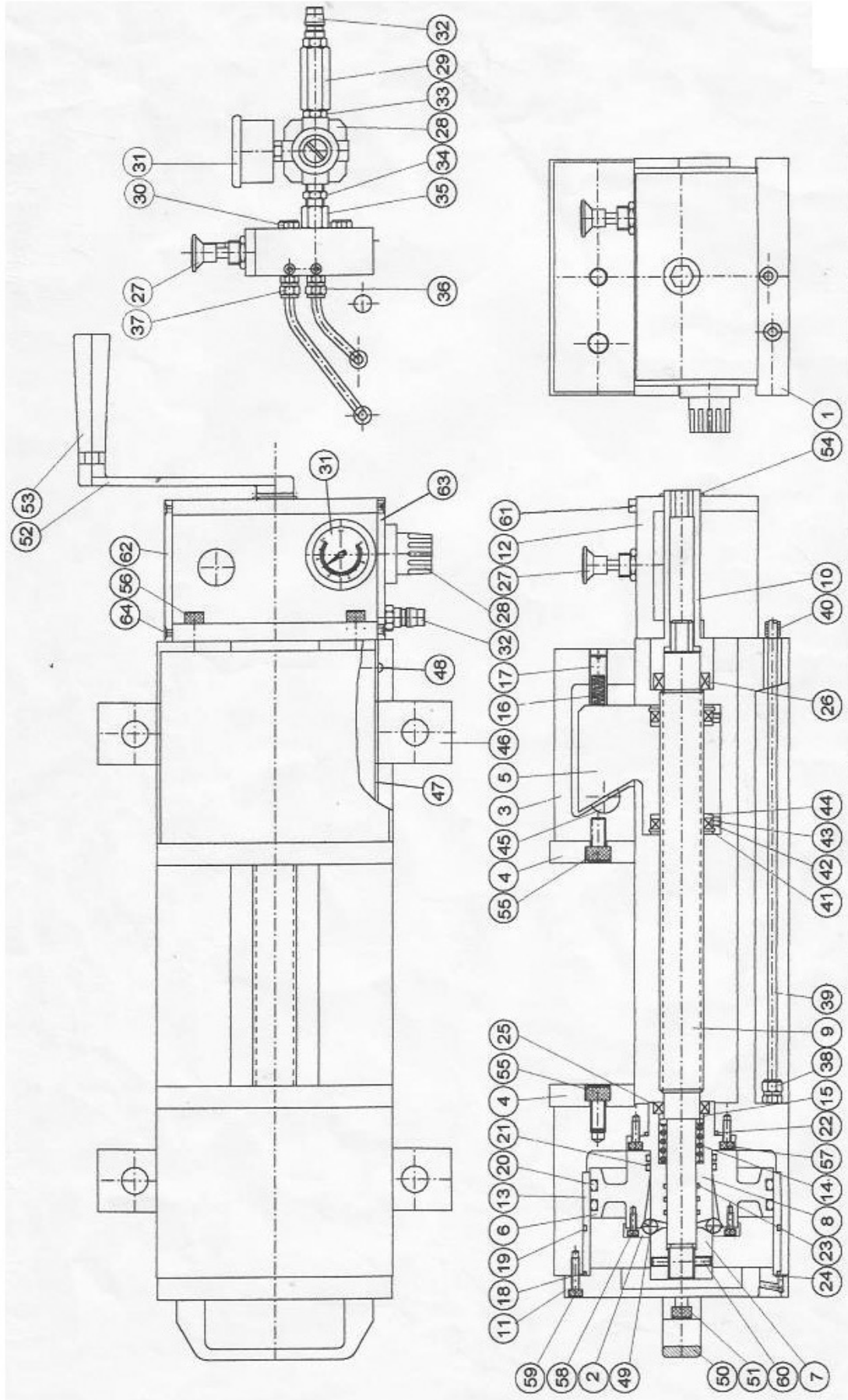

Table with 5 columns (A, B, H, L) and 12 rows listing dimensions for step guide key models.





SAFEWAY

DATE:27 July, 2005
Computer No:07700200

NO.	Computer No.	Part No.	Part Name	Q'ty	Specification		Remark
1	07700200-001	PQV-200-001	Main Body	1			
2	07700160-002	PQV-160-002	Steel Ball Cover	1			
3	07120200-003	CHV-200-003	Movable	1			
4	07120200-004	CHV-200-004	Jaw Plates	2			
5	07120200-005	CHV-200-005	Lock-Down Body	1			
6	07700200-003	PQV-200-003	Generate Power Piston	1			
7	07700160-004	PQV-160-004	Generate Power Taper	1			
8	07700200-005	PQV-200-005	Generate Power Holder	1			
9	07700200-006	PQV-200-006	Main Screw	1			
10	07700160-017	PQV-160-017	Main Screw Holder	1			
11	07700200-008	PQV-200-008	Cover	1			
12	07700200-018	PQV-200-018	Main Screw Support	1			
13	07700200-010	PQV-200-010	Piston Sleeve	1			
14	07700160-011	PQV-160-011	Spring	1			
15	07700160-012	PQV-160-012	Washer	1			
16	07120160-021	CHV-160-021	Spring	1			
17	07120160-022	CHV-160-022	Adjusting Screw	1			
18	OR-G-160	OR-G-160	O-Ring	1	G-160		
19	OR-G-160	OR-G-160	O-Ring	1	G-160		
20	OR-P-145	OR-P-145	O-Ring	2	P-145		
21	OR-P-42	OR-P-42	O-Ring	2	P-42		
22	OR-P-45	OR-P-45	O-Ring	1	P-45		
23	OR-P-20	OR-P-20	O-Ring	3	P-20		
24	OR-P-04	OR-P-04	O-Ring	1	P-04		
25	OS382508	OS382508	Oil-Seal	1	38x25x08		
26	OS382508	OS382508	Oil-Seal	1	38x25x08		
27	Mod. 358-910	Mod. 358-910	Operated Valves	1	358-910 camozzi		
28	M008-R00	M008-R00	Pressure Regulator	1	M008-R00 camozzi		
29	VNR-843-06	VNR-843-06	Unidirectional Valve	1	VNR-843-06		
30	SEP-1/8"	SEP-1/8"	Silencer	2	1/8"		
31	LED-1-1/2"x1/8"	LED-1-1/2"x1/8"	Pressure Gauge	1	10kg		
32	ZCPM-1/4"PT	ZCPM-1/4"PT	Tube Nipple	1	1/4"		
33	BCN-0202	BCN-0202	Connector	1	1/4"x1/4"		
34	BCN-0202	BCN-0202	Connector	1	1/4"x1/4"		
35	BFM-0201	BFM-0201	Nipple	1	1/4"x1/8"		
36	BCB-6M01	BCB-6M01	Tube Nipple	1	6mmx1/8"		
37	BCB-6M01	BCB-6M01	Tube Nipple	1	6mmx1/8"		
38	BCB-6M01	BCB-6M01	Tube Nipple	2	6mmx1/8"		
39	PU-TUBE-6x4	PU-TUBE-6x4	Air Tube	2	6x4mm		
40	SPRING	SPRING	Spring for chip	2			
41	SR-R-47	SR-R-47	Snap Ring	2	R-47		
42	07120200-020	CHV-200-020	Chip Seal	2			
43	SSM06X08L	SSM06X08L	Set Screw	2	M6x8L		



SAFEWAY

DATE:27 July. 2005
Computer No:07700200

Computer No.	Part No.	Part Name	Qty	Specification		Remark
WS6204	WS6204	Spring Washer	4	6204		
07800200-006	PHV-200-006	Semi-Sphere Segment	1			
07120160-025	CHV-160-025	Vise Clamp Block	4			
07700200-013	PQV-200-013	Name Plate(V)	2	PQV-200V		
07700200-013-1	PQV-200-013-1	Name Plate(S)	2	PQV-200S		
SDM04X08L	SDM04X08L	Round Socket Cap Screw	8	M4x8L		
SB10	SB10	Steel Ball	10	10mm		
M.443-CH-37101	M.443-CH-37101	Handle Grip	1			
SCM08x16L	SCM08x16L	Socket Cap Screw	2	M8x16L		
08100160-049	08100160-049	Handle	1			
GR-001	GR-001	Handle Grip	1	10mm		
SR-S-25	SR-S-25	Snap Ring	1	S-25		
SCM12X25L	SCM12x25L	Socket Cap Screw	4	M12x25L		
SCM10X25L	SCM10x25L	Socket Cap Screw	2	M10x25L		
SCM05X16L	SCM05x16L	Socket Cap Screw	4	M5x16L		
SCM05X10L	SCM05x10L	Socket Cap Screw	4	M5x10L		
SCM05X20L	SCM05x20L	Socket Cap Screw	8	M5x20L		
SSM06X10L	SSM06X10L	Set Screw	2	M6x10L		
SCM05X12L	SCM05x12L	Socket Cap Screw	1	M5x12L		
07700160-019	PQV-160-019	Right Cover	1			
07700160-020	PQV-160-020	Left Cover	1			
SFM04X08L	SFM04X08L	Flat Head Cap Screw	6	M4x8L		
07120200-032	CHV-200-032	Carton	1	CHV-200V		